

## NPN Transistors

### 2SC3646

#### ■ Features

- High breakdown voltage and large current capacity.
- Fast switching speed.
- Complementary to 2SA1416

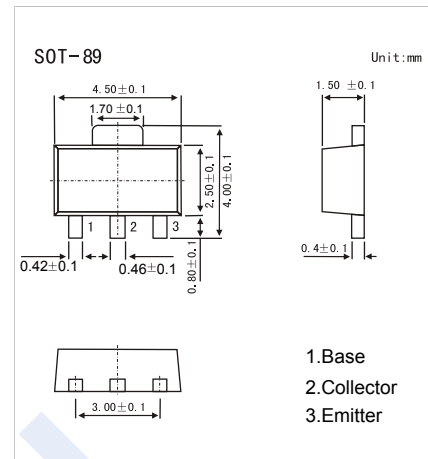

#### ■ Absolute Maximum Ratings $T_a = 25^\circ\text{C}$

Parameter	Symbol	Rating	Unit
Collector - Base Voltage	$V_{CB0}$	120	V
Collector - Emitter Voltage	$V_{CE0}$	100	
Emitter - Base Voltage	$V_{EB0}$	6	
Collector Current - Continuous	$I_C$	1	A
Peak Collector Current	$I_{CM}$	2	
Collector Power Dissipation	$P_C$	500	mW
Junction Temperature	$T_J$	150	$^\circ\text{C}$
Storage Temperature Range	$T_{stg}$	-55 to 150	

#### ■ Electrical Characteristics $T_a = 25^\circ\text{C}$

Parameter	Symbol	Test Conditions	Min	Typ	Max	Unit
Collector- base breakdown voltage	$V_{CB0}$	$I_C = 100 \mu\text{A}, I_E = 0$	120			V
Collector- emitter breakdown voltage	$V_{CE0}$	$I_C = 1 \text{ mA}, R_{BE} = \infty$	100			
Emitter - base breakdown voltage	$V_{EB0}$	$I_E = 100 \mu\text{A}, I_C = 0$	6			
Collector-base cut-off current	$I_{CBO}$	$V_{CB} = 100 \text{ V}, I_E = 0$			0.1	$\mu\text{A}$
Emitter cut-off current	$I_{EBO}$	$V_{EB} = 4 \text{ V}, I_C = 0$			0.1	
Collector-emitter saturation voltage	$V_{CE(sat)}$	$I_C = 400 \text{ mA}, I_B = 40 \text{ mA}$		0.1	0.4	V
Base - emitter saturation voltage	$V_{BE(sat)}$	$I_C = 400 \text{ mA}, I_B = 40 \text{ mA}$		0.85	1.2	
DC current gain	$h_{FE}$	$V_{CE} = 5 \text{ V}, I_C = 100 \text{ mA}$	100		400	
Turn-ON Time	$t_{on}$	See specified Test Circuit.		80		ns
Storage Time	$t_{stg}$			850		
Fall Time	$t_f$			50		
Collector output capacitance	$C_{ob}$	$V_{CB} = 10 \text{ V}, f = 1 \text{ MHz}$		8.5		pF
Transition frequency	$f_T$	$V_{CE} = 10 \text{ V}, I_C = 100 \text{ mA}$		120		MHz

#### ■ Classification of $h_{FE}$

Marking	CBR	CBS	CBT
Range	100-200	140-280	200-400

## NPN Transistors

### 2SC3646

#### Switching Time Test Circuit

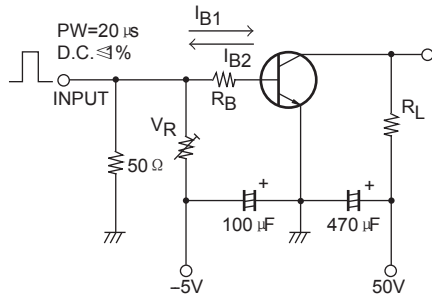

$I_C = 10I_{B1} = -10I_{B2} = 400\text{mA}$   
 (For PNP, the polarity is reversed)

#### Typical Characteristics

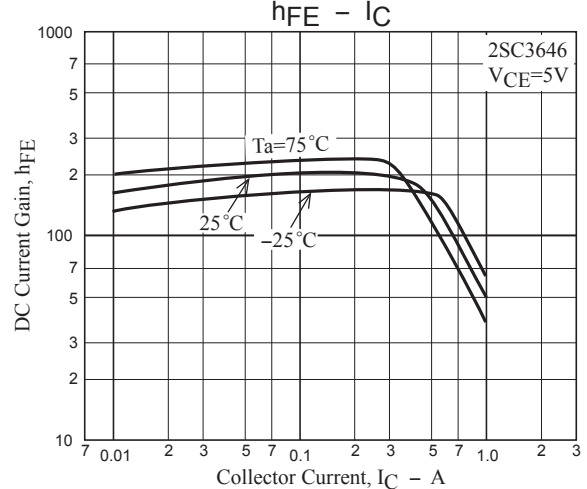
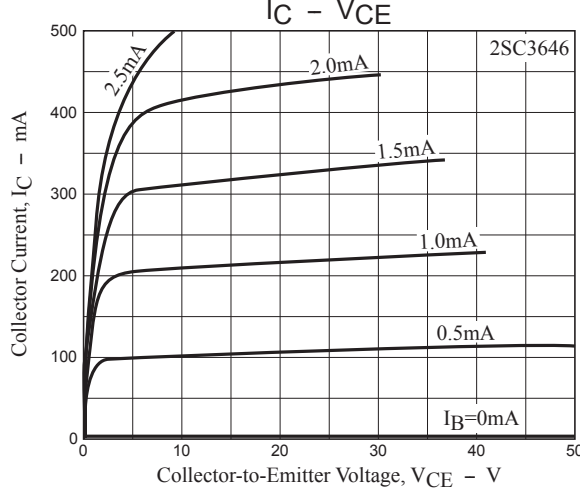
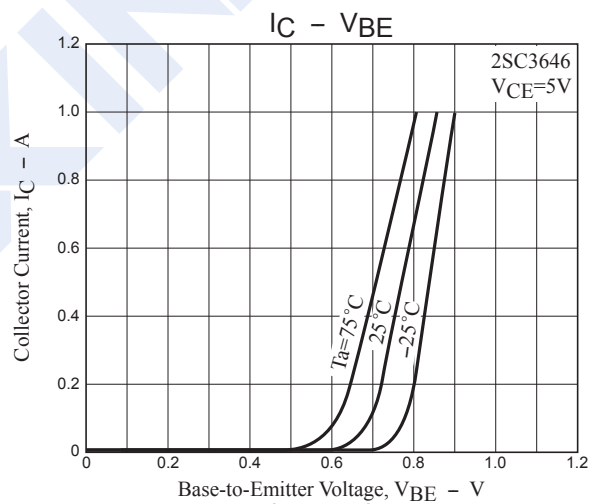
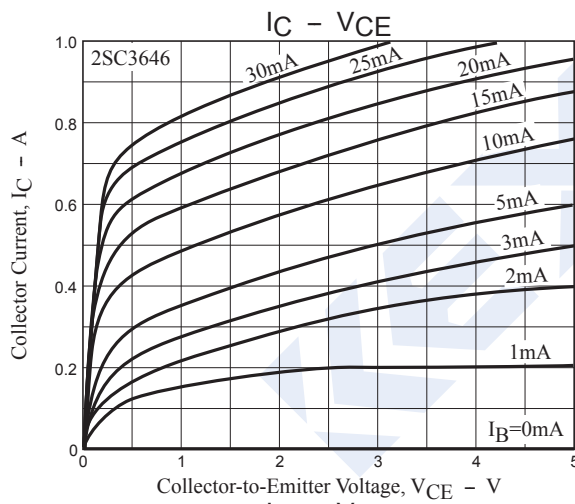

# NPN Transistors

## 2SC3646

### Typical Characteristics

