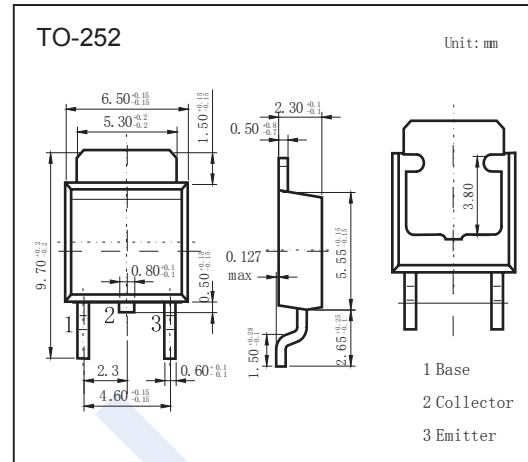

PNP Transistors

2SB931

■ Features

- Low collector to emitter saturation voltage $V_{CE(sat)}$
- Satisfactory linearity of forward current transfer ratio h_{FE}
- Large collector current I_C
- Complementary to 2SD1254

■ Absolute Maximum Ratings $T_a = 25^\circ\text{C}$

Parameter	Symbol	Rating	Unit	
Collector - Base Voltage	V_{CB0}	-130	V	
Collector - Emitter Voltage	V_{CE0}	-80		
Emitter - Base Voltage	V_{EB0}	-7		
Collector Current - Continuous	I_C	-3	A	
Collector current - Pulse	I_{CP}	-6		
Collector Power Dissipation	P_C	$T_c = 25^\circ\text{C}$	30	W
		$T_a = 25^\circ\text{C}$	1.3	
Junction Temperature	T_J	150	$^\circ\text{C}$	
Storage Temperature range	T_{stg}	-55 to 150		

■ Electrical Characteristics $T_a = 25^\circ\text{C}$

Parameter	Symbol	Test Conditions	Min	Typ	Max	Unit
Collector- base breakdown voltage	V_{CB0}	$I_C = -100 \mu\text{A}, I_E = 0$	-130			V
Collector- emitter breakdown voltage	V_{CE0}	$I_C = -10 \text{ mA}, I_B = 0$	-80			
Emitter - base breakdown voltage	V_{EB0}	$I_E = -100 \mu\text{A}, I_C = 0$	-7			
Collector-base cut-off current	I_{CBO}	$V_{CB} = -100\text{V}, I_E = 0$			-10	μA
Emitter cut-off current	I_{EBO}	$V_{EB} = -5\text{V}, I_C = 0$			-50	
Collector-emitter saturation voltage	$V_{CE(sat)}$	$I_C = -2 \text{ A}, I_B = -100\text{mA}$			-0.5	V
Base - emitter saturation voltage	$V_{BE(sat)}$	$I_C = -2 \text{ A}, I_B = -100\text{mA}$			-1.5	
DC current gain	$h_{FE(1)}$	$V_{CE} = -2\text{V}, I_C = -100\text{mA}$	45			
	$h_{FE(2)}$	$V_{CE} = -2\text{V}, I_C = -500\text{mA}$	90		260	
Turn-on time	t_{on}	$I_C = -0.5\text{A}, I_{B1} = -50\text{mA}, I_{B2} = 50\text{mA}$		0.3		μs
Storage time	t_{stg}			1.1		
Fall time	t_f			0.3		
Transition frequency	f_T	$V_{CE} = -10\text{V}, I_C = -500\text{mA}, f = 10\text{MHz}$		30		MHz

■ Classification of $h_{FE(2)}$

Type	2SB931-Q	2SB931-P
Range	90-180	130-260

PNP Transistors

2SB931

■ Typical Characteristics

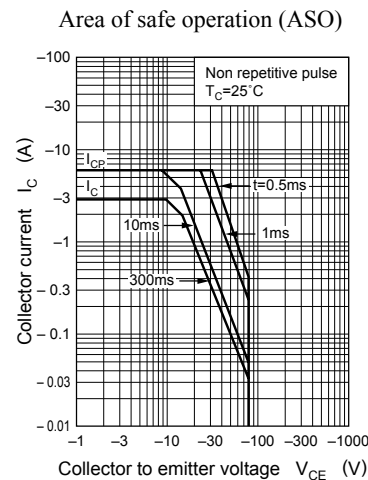
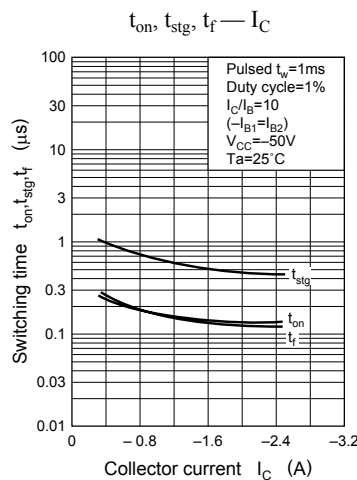
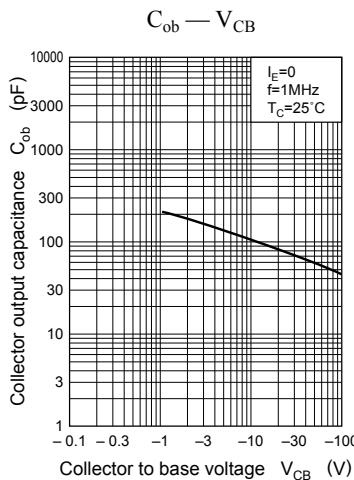
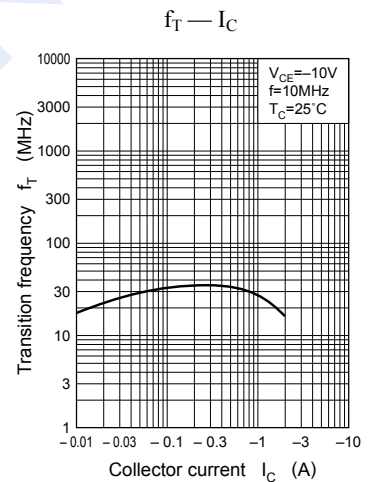
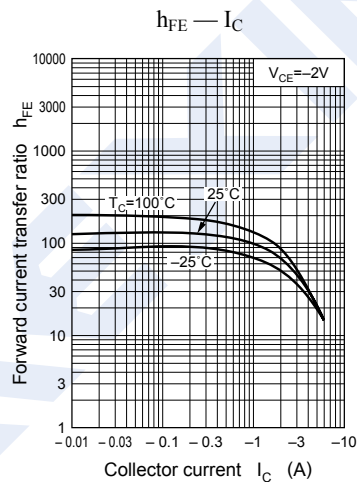
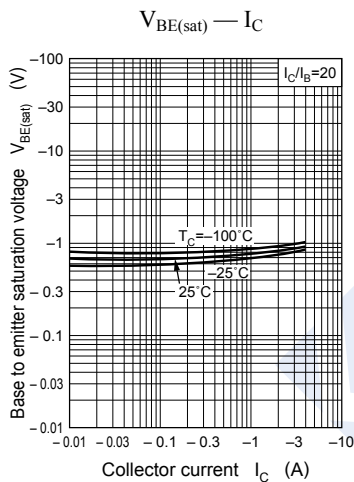
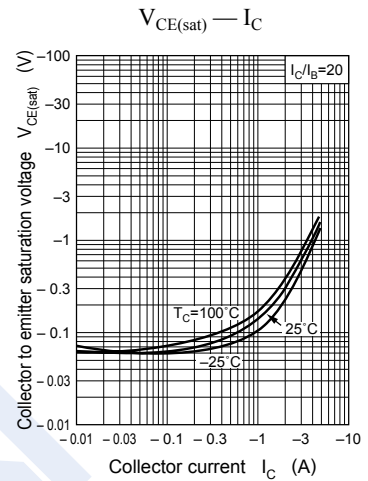
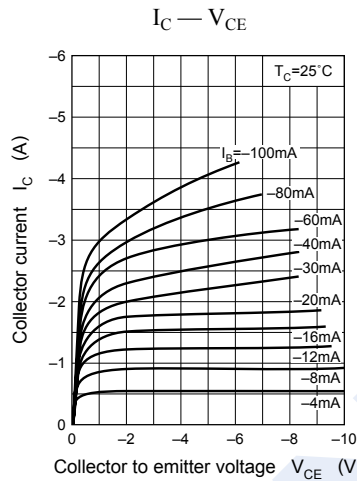
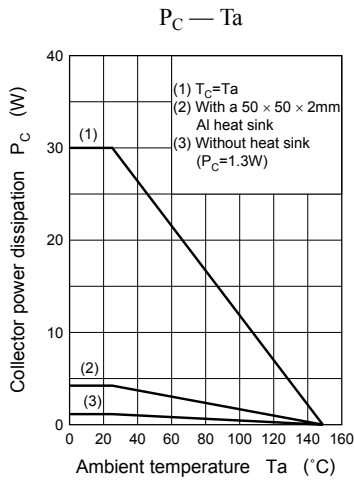

PNP Transistors

2SB931

■ Typical Characteristics

