

PNP Transistors

2SA1418

■ Features

- Adoption of FBET, MBIT Processes
- High Breakdown Voltage and Large Current Capacity
- Fast Switching Speed
- Complementary to 2SC3648

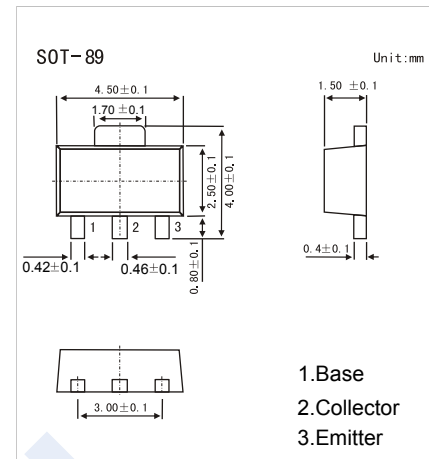

■ Absolute Maximum Ratings Ta = 25°C

Parameter	Symbol	Rating	Unit
Collector - Base Voltage	V _{CB0}	-180	V
Collector - Emitter Voltage	V _{CEO}	-160	
Emitter - Base Voltage	V _{EBO}	-6	
Collector Current - Continuous	I _C	-0.7	A
Collector Current - Pulsed	I _{CP}	-1.5	
Collector Power Dissipation	P _C	500	mW
Junction Temperature	T _J	150	°C
Storage Temperature range	T _{stg}	-55 to 150	

■ Electrical Characteristics Ta = 25°C

Parameter	Symbol	Test Conditions	Min	Typ	Max	Unit
Collector- base breakdown voltage	V _{CB0}	I _C = -100 μA, I _E =0	-180			V
Collector- emitter breakdown voltage	V _{CEO}	I _C = -1 mA, R _{BE} =∞	-160			
Emitter - base breakdown voltage	V _{EBO}	I _E = -100 μA, I _C =0	-6			
Collector-base cut-off current	I _{CB0}	V _{CB} = -120 V, I _E =0			-0.1	μA
Emitter cut-off current	I _{EBO}	V _{EB} = -4V, I _C =0			-0.1	
Collector-emitter saturation voltage	V _{CE(sat)}	I _C =-250mA, I _B =- 25mA		-0.2	-0.5	V
Base - emitter saturation voltage	V _{BE(sat)}	I _C =-250mA, I _B =- 25mA		-0.85	-1.2	
DC current gain	h _{FE}	V _{CE} = -5V, I _C = -100mA	100		400	
Turn-on time	t _{on}	See Test Circuit.		60		ns
Storage time	t _s			900		
Fall time	t _f			60		
Output capacitance	C _{ob}	V _{CB} = -10V, I _E = 0, f=1MHz		11		pF
Transition frequency	f _T	V _{CE} = -10V, I _E = -50mA		120		MHz

■ Classification of h_{FE}

Type	2SA1418-R	2SA1418-S	2SA1418-T
Range	100-200	140-280	200-400
Marking	ADR*	ADS*	ADT*

PNP Transistors 2SA1418

Test Circuit

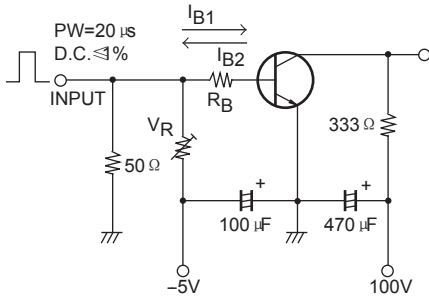

$I_C = 20I_{B1} = -20I_{B2} = 300\text{mA}$
(For PNP, the polarity is reversed)

Typical Characteristics

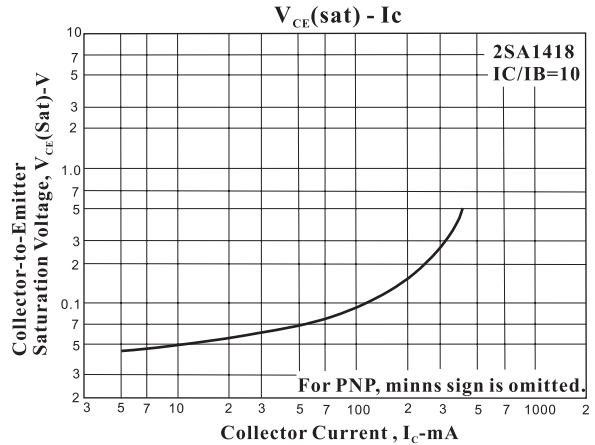
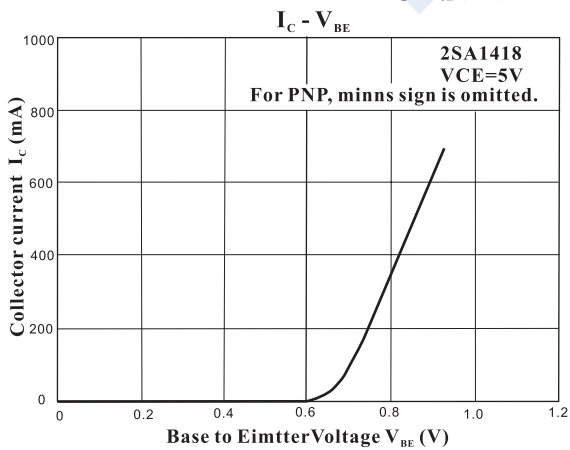
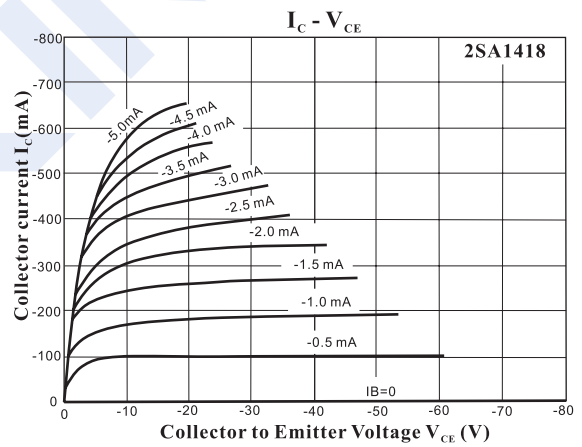
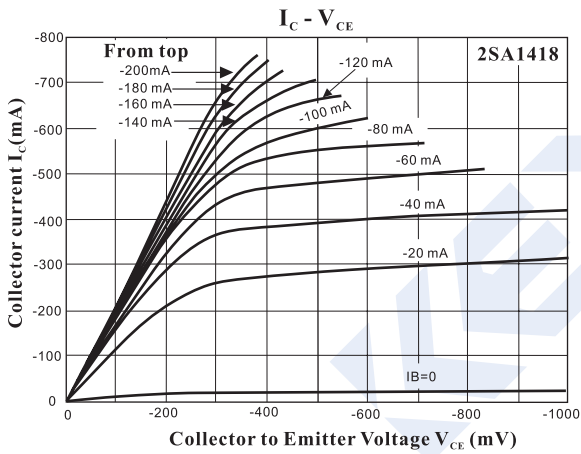

PNP Transistors

2SA1418

■ Typical Characteristics

